

Service Manual

FM/AM Stereo Tuner
ST-7200
 (X), (XG), (XGH), (XE)



TECHNICAL SPECIFICATIONS (IHF) Specifications are subject to change without notice for further improvement.

FM TUNER SECTION

Frequency range:	88~108MHz
Antenna terminals:	300Ω (balanced) 75Ω (unbalanced)
Sensitivity:	2μV
Total harmonic distortion (400Hz, 100% modulation):	MONO 0.2% STEREO 0.4%
S/N:	75dB
Frequency response:	20Hz~15kHz ±0.7dB
Alternate channel selectivity:	70dB
Capture ratio:	1.0dB
Image rejection (at 98MHz):	55dB
IF rejection (at 98MHz):	80dB
Spurious response rejection (at 98MHz):	85dB
AM suppression:	55dB

Stereo separation:	45dB at 1kHz 35dB at 10kHz
Leak carrier (19kHz, 38kHz):	-65dB

AM TUNER SECTION

Frequency range:	525~1605kHz
Sensitivity:	30μV
Selectivity:	25dB
Image rejection (at 1000kHz):	45dB
IF rejection (at 1000kHz):	40dB

GENERAL

Output voltage:	0.7V
Power supply:	50/60Hz 110/120/220/240V
Power consumption:	9W
Dimensions (W×H×D):	410×140×352mm (16 1/8"×5 1/2"×13 7/8")
Weight:	4.8kg (10.58lb.)

TECHNISCHE DATEN (DIN 45 500) Spezifikationen können infolge von Verbesserungen ohne Ankündigung geändert werden.

UKW-TUNERTEIL

Empfangsbereich:	88~108MHz
Antennenanschluss:	300Ω (symmetrisch) 75Ω (asymmetrisch)
Empfindlichkeit:	2.0μV, 30dB Fremdspannungsabstand 300Ω 1.4μV, 20dB Fremdspannungsabstand 300Ω 1.0μV, 30dB Fremdspannungsabstand 75Ω 0.7μV, 20dB Fremdspannungsabstand 75Ω
Fremdspannungsabstand:	MONO 68dB STEREO 60dB
Frequenzgang:	20Hz~15kHz, ±0.7dB
Selektivität:	70dB
Gleichwellen-Selektion:	1.0dB
Harmonische Verzerrung:	MONO 0.2% STEREO 0.4%
Spiegelselektion bei 98MHz:	55dB
ZF-Festigkeit bei 98MHz:	80dB
Unselektivitätsfestigkeit bei 98MHz:	85dB

AM-Unterdrückung:	55dB
Stereo-Übersprechdämpfung:	45dB bei 1kHz, 35dB bei 10kHz
Trägerrest:	-65dB
Begrenzung, Einsatzzpunkt:	1.2μV
Bandbreite:	ZF-Verstärker 250kHz UKW-Demodulator 820kHz

MW-TUNERTEIL

Empfangsbereich:	525~1605kHz
Empfindlichkeit:	30μV
Selektivität:	25dB
Spiegelselektion:	45dB
ZF-Festigkeit:	40dB

ALLGEMEINE DATEN

Ausgangsspannung:	0.7V
Leistungsaufnahme:	9W
Netzspannung umschaltbar:	110/120/220/240V
Abmessungen (B×H×T):	410×140×352mm
Gewicht:	4.8kg

SERVICE AID

FM soft muting

Concerning the muting of this unit, when the tuning point is gradually moved away from the point of full output and the output gradually decreases, there will soon be no output. Thus, rather than output suddenly changing from zero to maximum, and from maximum output suddenly to zero, the sound gradually fades away and, for the listener, the listening sensation is more natural and more pleasant.

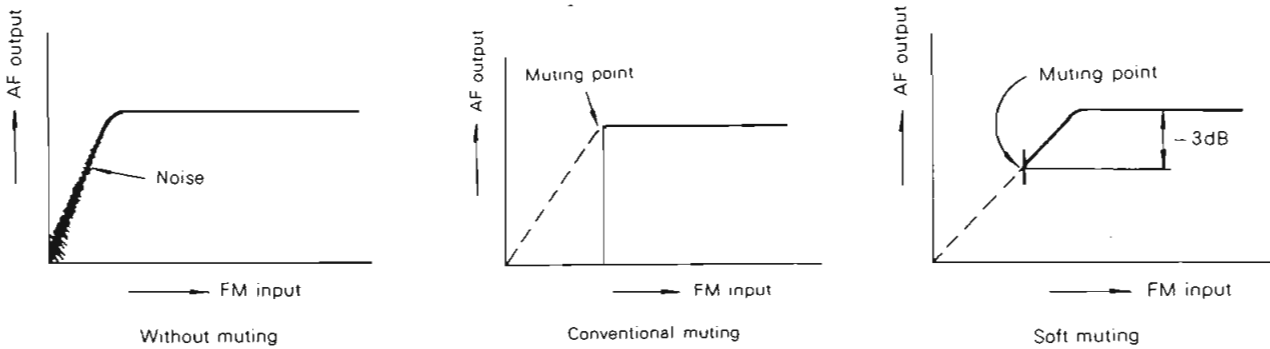

Circuitry principles

This circuitry makes use of the V_{BE} characteristics of TR106 2SA733. The detected voltage of the FM IF signal is applied to the base of 2SA733. When the FM input signal is amplified, the voltage is also amplified. Because the emitter current also increases when the base voltage is amplified, the voltage of the collector approaches the value of B voltage.

Because this collector is connected to the 6th FM IF amplifier via the muting switch, a change in the collector voltage limits the output of the 6th IF amplifier. When the FM input signal is amplified and the base voltage of TR106 reaches the operation point (about 0.6V), the output reaches maximum without restriction.

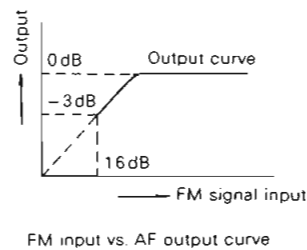
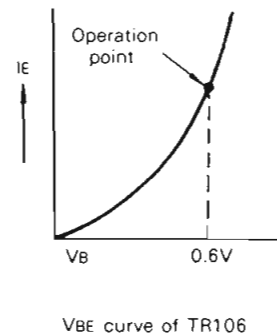
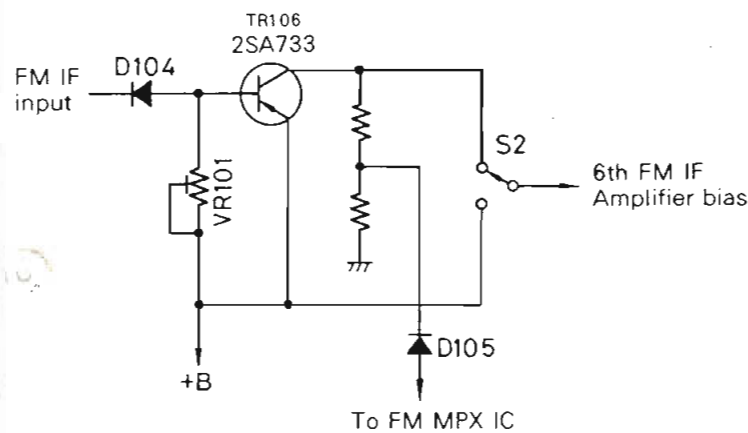

Adjustment of the soft muting circuitry

- (1) Apply 60 dB FM signal to antenna terminal.
- (2) AF signal level at output terminal should then be 0 dB.
- (3) Reduce FM signal applied to antenna terminal to 16 dB.
- (4) Adjust VR101 so that the output is then 3 dB less than the previous output (when input was 60 dB).

ALIGNMENT INSTRUCTIONS

Notes:					
1. Muting switch OFF		4. Maintain line voltage at rated voltage.			
2. Band selector switch AM, FM AUTO (FM-RF, FM-IF)		5. Output of signal generator should be no higher than necessary to obtain an output reading.			
3. 300Ω FM dummy antenna Refer to fig. 1.					
SIGNAL GENERATOR or SWEEP GENERATOR		DIAL SETTING	INDICATOR (VTVM or SCOPE)	ADJUSTMENT POINTS	REMARKS
CONNECTION	FREQUENCY		[DISTORTION METER]		
AM ALIGNMENT					
1	High side through 0.001μF to TP0, Common to chassis.	455kHz (Set for England to 470kHz)	Point of non-interference	T201 (1st IFT) T202 (2nd IFT)	Adjust for maximum output.
2	Fashion loop of several turns of wire and radiate signal into loop of tuner.	550kHz (30% Mod. with 400Hz)	550kHz	L202 (OSC Coil) L201 (ANT Coil)	Adjust for maximum output Adjust ferrite core of L201 by screw driver.
3	Fashion loop of several turns of wire and radiate signal into loop of tuner.	1500kHz (30% Mod. with 400Hz)	1500kHz	CT202 (OSC Trimmer) CT201 (ANT Trimmer)	Adjust for maximum output. Repeat steps (2) and (3).
FM-IF ALIGNMENT					
4	No Signal	Point of non-interference	Connect vertical amplifier of scope to output terminal of set.	T101 (DISCRI IFT)(P) Brown Core	Adjust for maximum noise level.
5	No Signal	Point of non-interference	Tuning meter of set.	T101 (DISCRI IFT)(S) Green Core	Adjust for center position.
FM-RF ALIGNMENT					
6	Connect to FM antenna terminal through FM dummy antenna.	90MHz (100% Mod. with 400Hz)	90MHz	L4 (OSC Coil) L2 (DET Coil) L1 (ANT Coil)	Adjust for maximum output.
7	Connect to FM antenna terminal through FM dummy antenna.	98MHz (100% Mod. with 400Hz)	106MHz	CT3 (OSC Trimmer) CT2 (DET Trimmer) CT1 (ANT Trimmer)	Adjust for maximum output. Repeat steps (6) and (7).
FM MONO DISTORTION ALIGNMENT					
8	Connect to FM antenna terminal through FM dummy antenna.	98MHz (100% Mod. with 400Hz)	98MHz	T101 (DISCRI IFT)(P) Brown Core	Adjust for minimum of distortion meter indication.
MUTING IF ALIGNMENT					
9	Connect to FM antenna terminal through FM dummy antenna. Apply signal of 22dB level [IHF].	98MHz (100% Mod. with 400Hz)	98MHz	T102 (MUTING IFT) Primary T103 (MUTING IFT) Secondary	Adjust for maximum of DC voltmeter indication.
SOFT MUTING ALIGNMENT					
Refer to Service Aid.					
FM MPX PILOT ALIGNMENT					
When use the frequency counter			When not use the frequency counter		
① 98MHz Non-modulation mono signal applied to set. ② Muting switch to ON. ③ Connect the frequency counter to TP301 through resistor (100kΩ). ④ Adjust VR301 to 19kHz ±30Hz.			① Stereo signal applied to set or receive the stereo station. ② Adjust VR301 to lighting point of stereo indicator and sement contactor of VR301 as shown fig. 2.		
STEREO SEPARATION ALIGNMENT					
Note: 1. Stereo modulator Connect stereo modulator output to EXT. MOD. terminal of signal generator. Internal OSC 1kHz Pilot signal modulation 10% 2. Signal generator Frequency approximately 98MHz. Output level 72dB (IHF), Modulation mode to FM. 3. Band selector switch FM AUTO					
SIGNAL GENERATOR CONNECTION	STEREO MODULATOR MODE and MOD. RATE	INDICATOR (VTVM or SCOPE)	ADJUSTMENT POINTS	REMARKS	
FM antenna terminal through dummy antenna.	L (and R) 30% Modulation	Connect VTVM or scope to output terminals through low pass filter.	VR401	Adjust for minimum right (and left) output.	

ALIGNMENT POINT

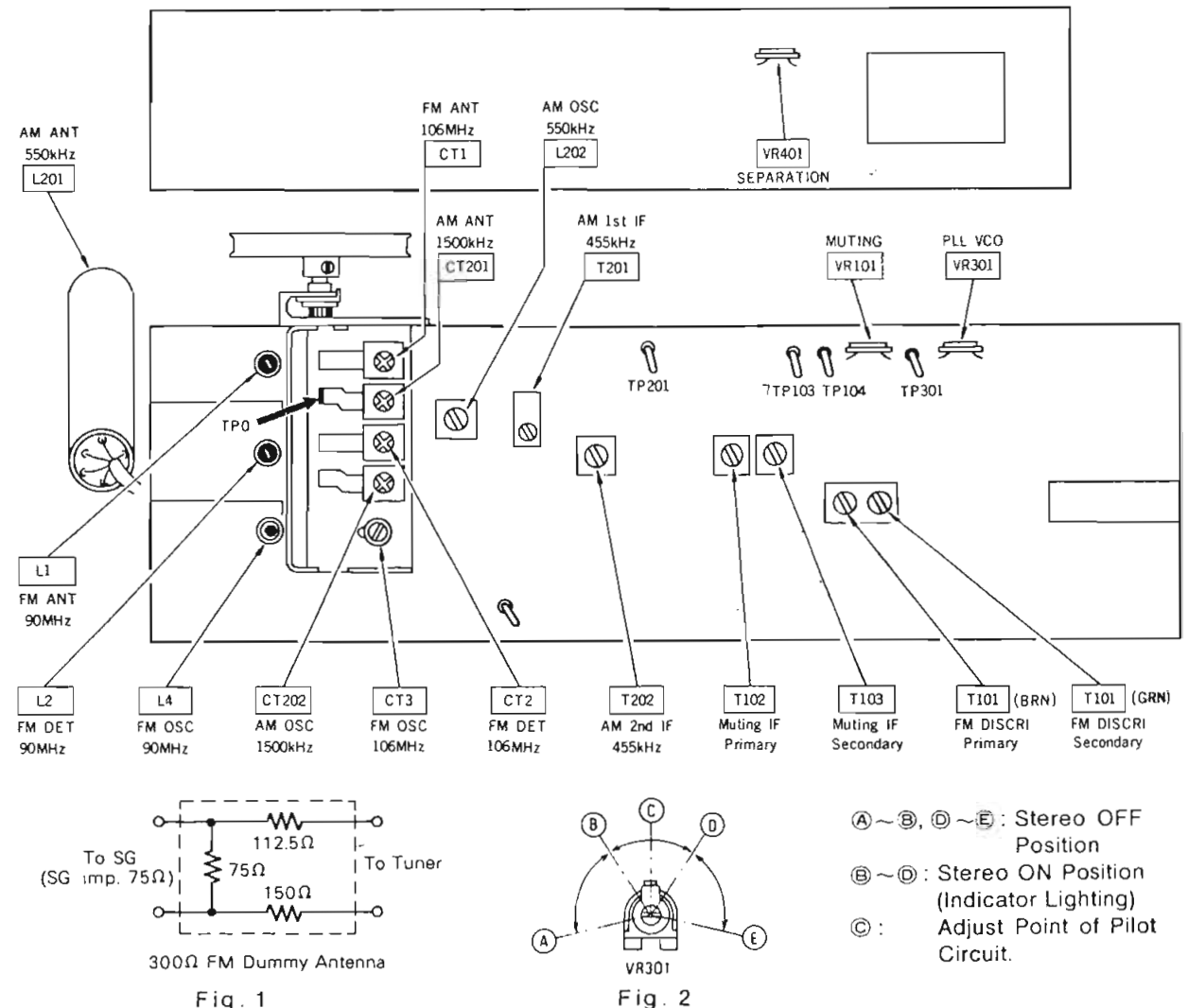

DIAL CORD INSTALLATION GUIDE

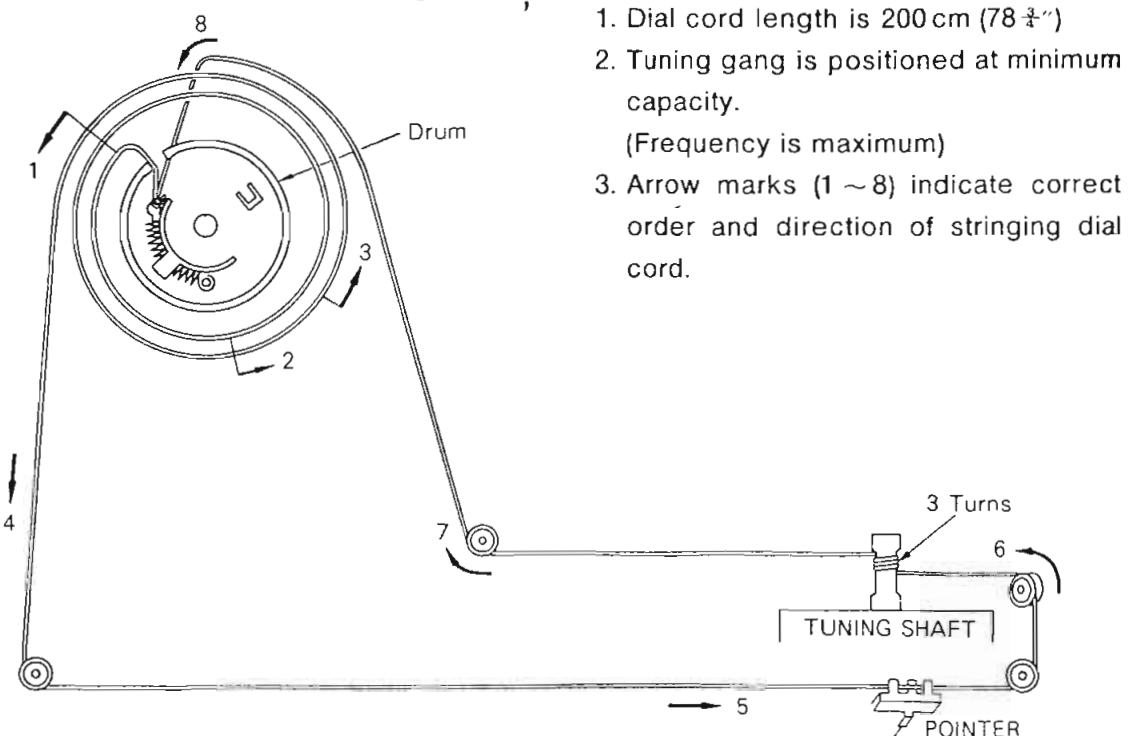

- Dial cord length is 200 cm (78 3/4").
- Tuning gang is positioned at minimum capacity. (Frequency is maximum)
- Arrow marks (1 ~ 8) indicate correct order and direction of stringing dial cord.

Schematic Diagram.....Model ST-7200

(This schematic diagram may be modified at any time with the development of new technology.)

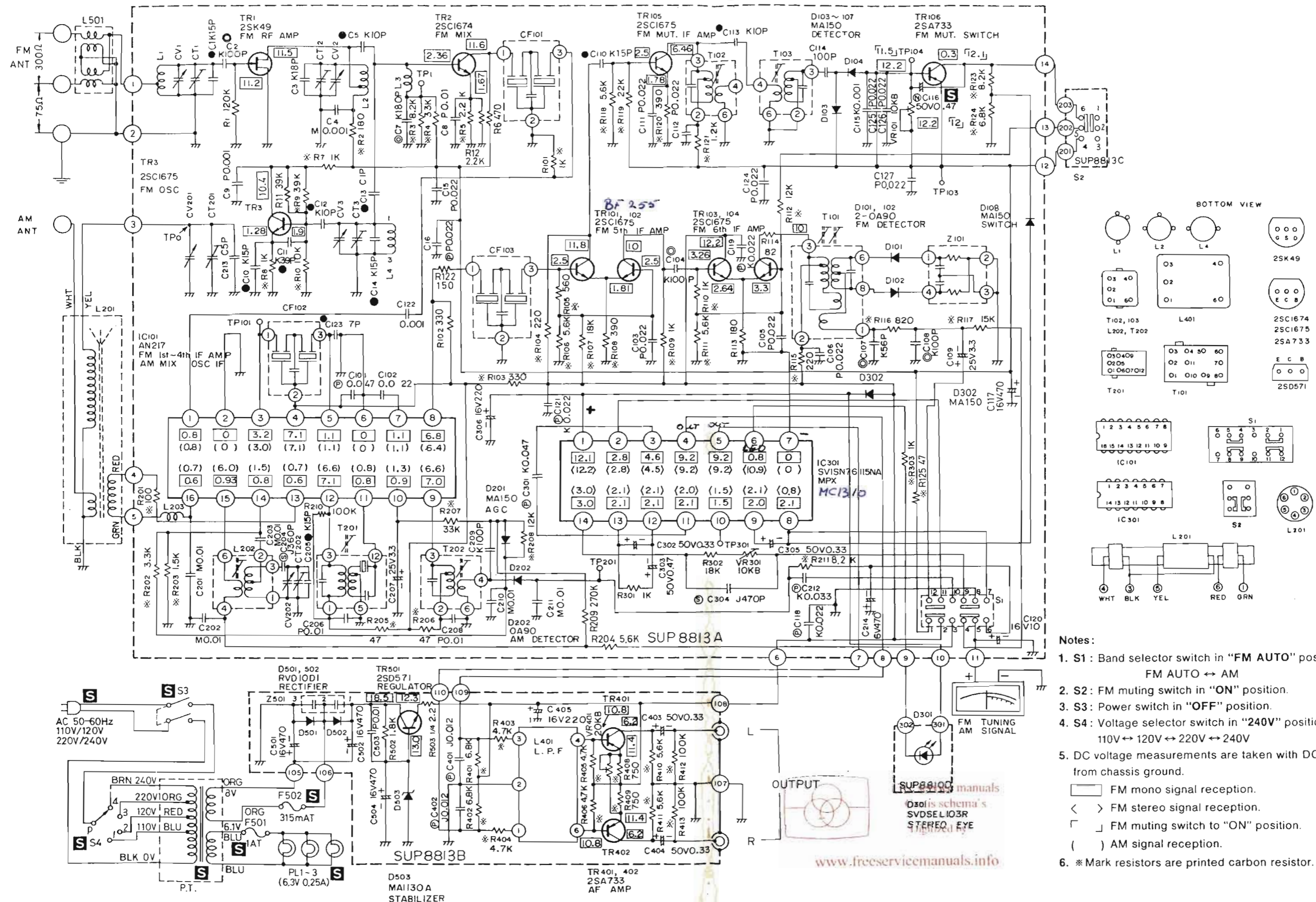

- Notes:**
1. S1 : Band selector switch in "FM AUTO" position.
FM AUTO ↔ AM
 2. S2 : FM muting switch in "ON" position.
 3. S3 : Power switch in "OFF" position.
 4. S4 : Voltage selector switch in "240V" position.
110V ↔ 120V ↔ 220V ↔ 240V
 5. DC voltage measurements are taken with DC VTVM from chassis ground.
- FM mono signal reception.
 < > FM stereo signal reception.
 ┌ ┐ FM muting switch to "ON" position.
 () AM signal reception.
6. * Mark resistors are printed carbon resistor.

Printed Circuit Board (Bottom View)Model ST-7200

Printed Carbon Resistor Circuit View on Top of P.C.B

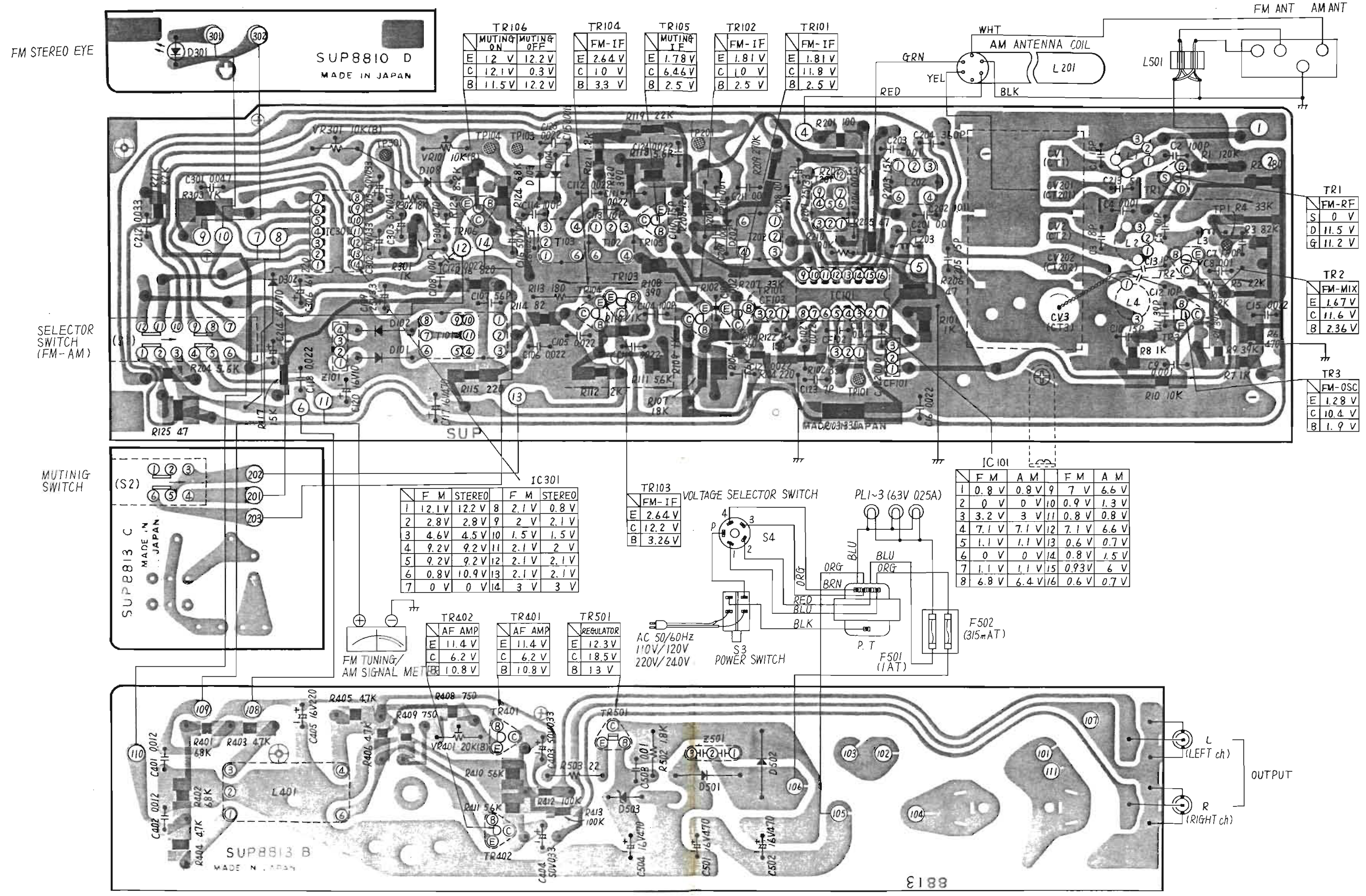

TR106		TR104		TR105		TR102		TR101	
MUTING ON	MUTING OFF	FM-IF		MUTING IF		FM-IF		FM-IF	
E	12.2 V	E	2.64 V	E	1.78 V	E	1.81 V	E	1.81 V
C	12.1 V	C	10 V	C	6.46 V	C	10 V	C	11.8 V
B	11.5 V	B	3.3 V	B	2.5 V	B	2.5 V	B	2.5 V

TR1	
FM-RF	
S	0 V
D	11.5 V
G	11.2 V

TR2	
FM-MIX	
E	1.67 V
C	11.6 V
B	2.36 V

TR3	
FM-OSC	
E	1.28 V
C	10.4 V
B	1.9 V

IC301			
F	M	STEREO	
1	12.1 V	12.2 V	8
2	2.8 V	2.8 V	9
3	4.6 V	4.5 V	10
4	9.2 V	9.2 V	11
5	9.2 V	9.2 V	12
6	0.8 V	10.9 V	13
7	0 V	0 V	14

TR103	
FM-IF	
E	2.64 V
C	12.2 V
B	3.26 V

IC101			
F	M	A	M
1	0.8 V	0.8 V	9
2	0 V	0 V	10
3	3.2 V	3 V	11
4	7.1 V	7.1 V	12
5	1.1 V	1.1 V	13
6	0 V	0 V	14
7	1.1 V	1.1 V	15
8	6.8 V	6.4 V	16

TR402		TR401		TR501	
AF AMP		AF AMP		REGULATOR	
E	11.4 V	E	11.4 V	E	12.3 V
C	6.2 V	C	6.2 V	C	18.5 V
B	10.8 V	B	10.8 V	B	13 V

LOCATION OF CONTROLS

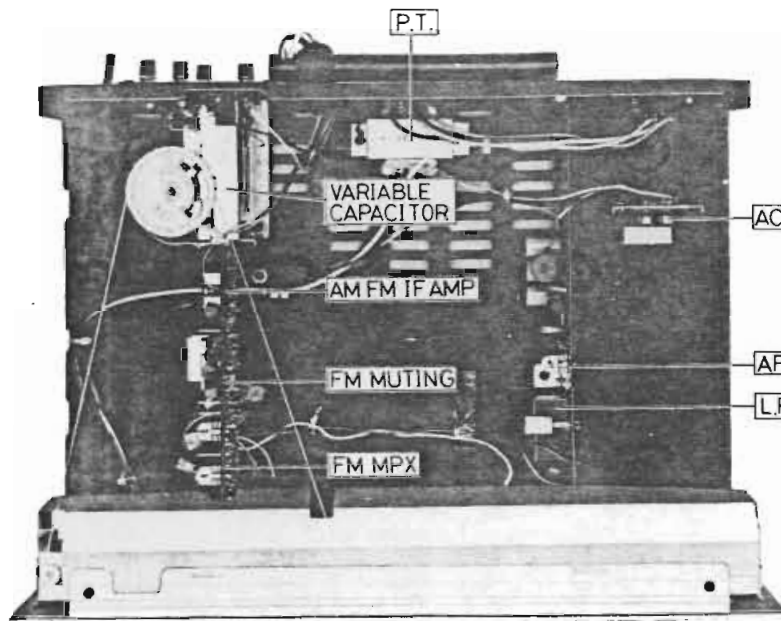
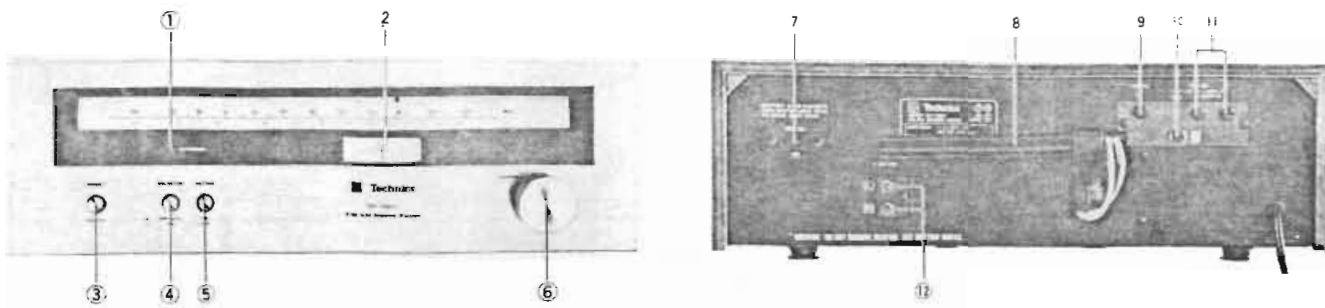

- ① FM STEREO INDICATOR
- ② FM TUNING & AM SIGNAL METER
- ③ POWER SWITCH
- ④ BAND SELECTOR SWITCH
- ⑤ FM MUTING SWITCH
- ⑥ TUNING CONTROL
- ⑦ VOLTAGE SELECTOR SWITCH
- ⑧ AM FERRITE ANTENNA COIL
- ⑨ AM ANTENNA TERMINAL
- ⑩ GROUND TERMINAL
- ⑪ FM ANTENNA TERMINALS (300Ω)
- ⑬ AF OUTPUT TERMINALS

PACKING PARTS

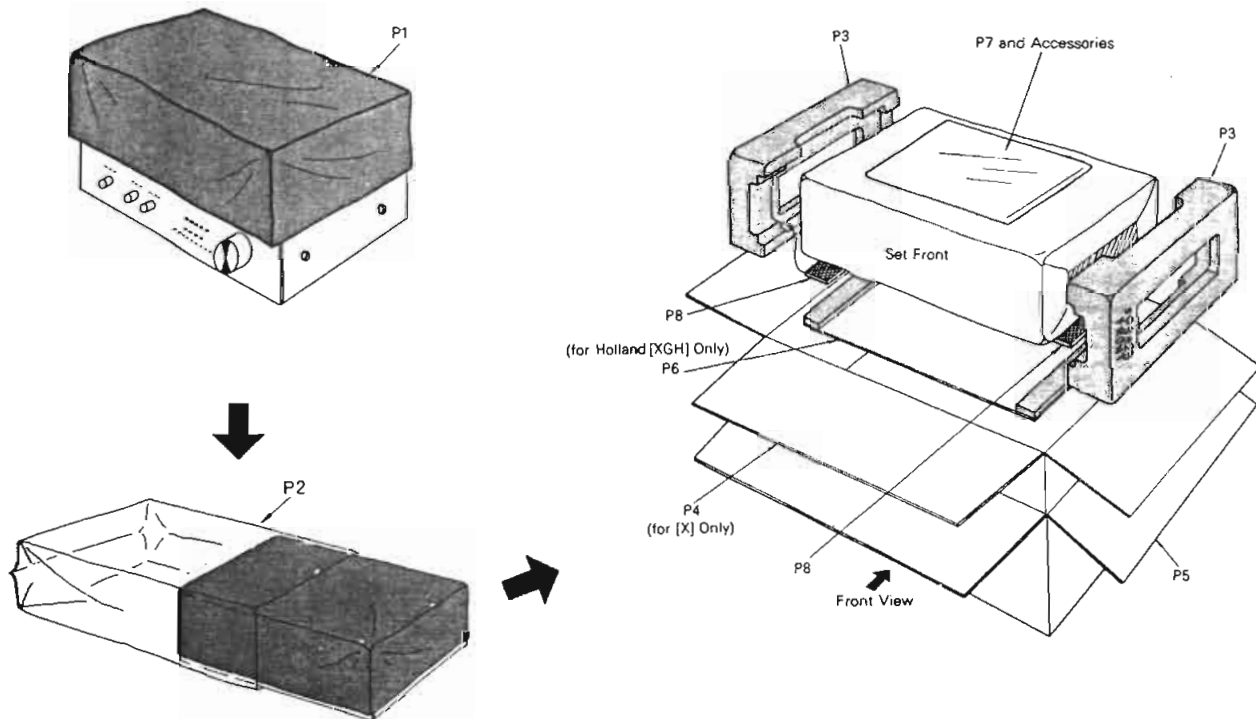

TO REMOVE CABINET

- (1) Remove four (4) cabinet mounting screws (side) Nos 1-4, as shown in fig. 1.
- (2) Remove metal fitting of cabinet from holes A and B of front panel in arrow direction ①, as shown in fig. 1.
- (3) Remove cabinet from chassis in arrow direction ②, as shown in fig. 1.
- (4) To reassemble, reverse above procedure.

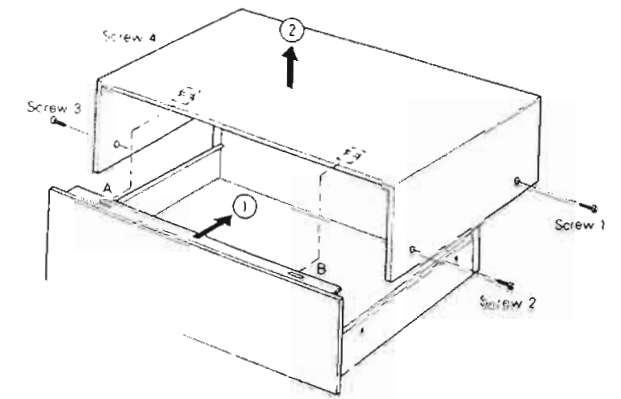
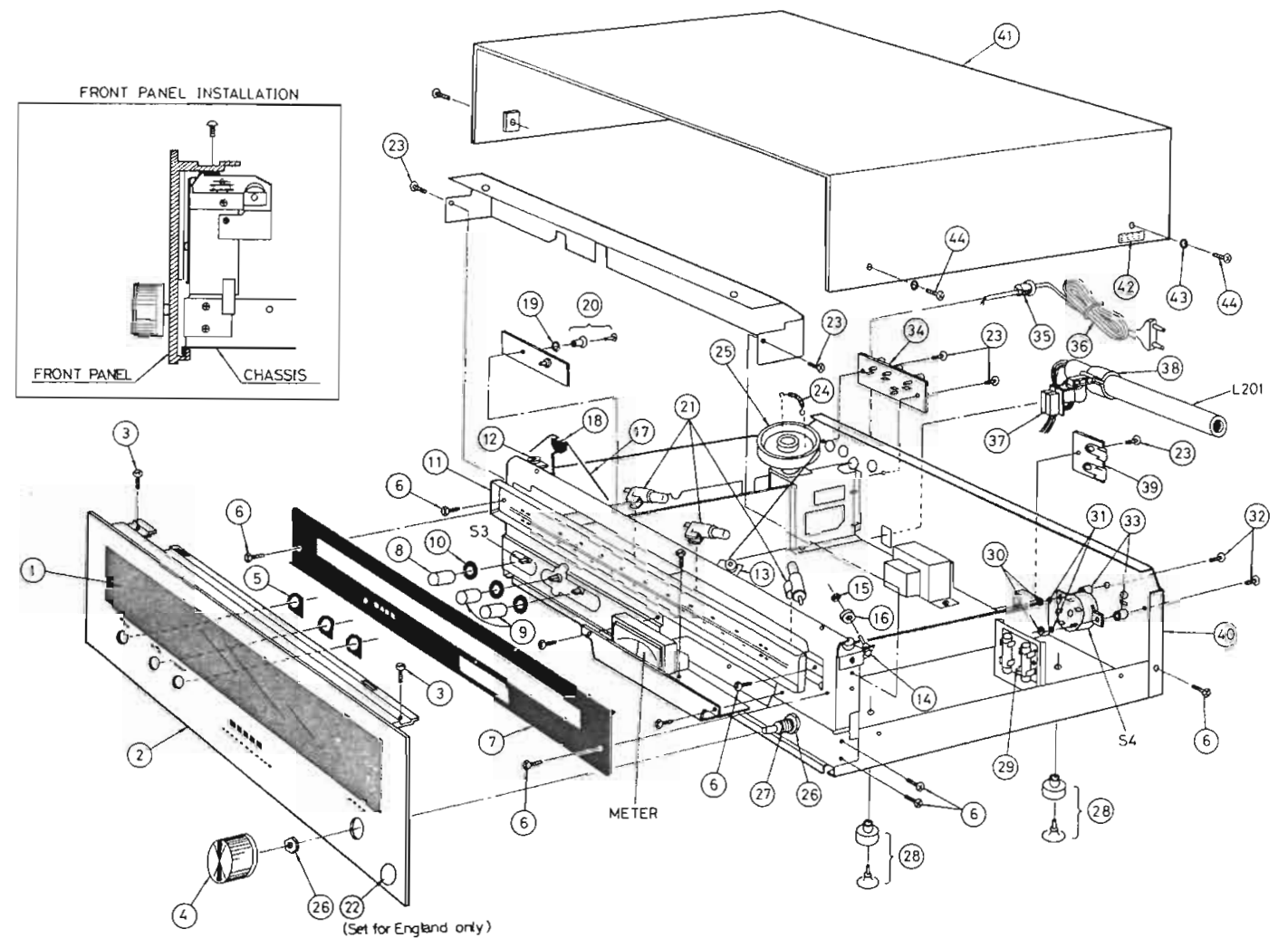
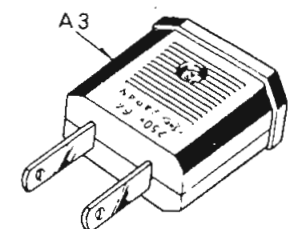
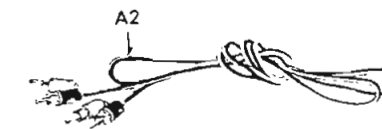
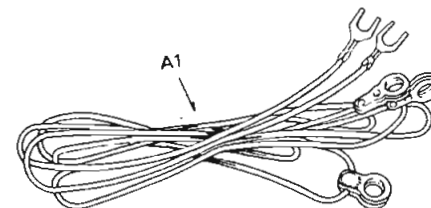

Fig. 1

CABINET & CHASSIS PARTS LOCATION



ACCESSORIES



(Set for [X] only)

REPLACEMENT PARTS LIST

NOTES : 1. Part numbers are indicated on most mechanical parts.
Please use this part number for parts orders.
2. **SAFETY** Indicates, for safety reasons, that only parts specified in service manual be used for replacement

Ref. No.	Part No.	Part Name & Description	Per Set	Remarks
INTEGRATED CIRCUITS				
IC101 IC301	AN217BB SVISN76115NA	FM IF, AM OSC, MIX & IF Amp. PLL Type FM MPX	1 1	
TRANSISTORS				
TR1 TR2 TR3,101~105 TR106,401,402 TR501	2SK49-H2 2SC1674-M 2SC1675-L1 2SA733-P1 2SD571-L	FM RF Amplifier [FET] FM Mixer FM OSC & IF Amplifier Muting Switch & AF Amplifier Regulator	1 1 6 3 1	
DIODES				
D101,102 D103,104,105, 201,302 D202 D501,502 D503 D301	2-OA90 MA150 OA90 RVD10D1 MA1130A SVDSEL103R	FM Discriminator (Detector) Muting Detector & AGC AM Detector Rectifier 13V Zener Stereo Indicator, L.E.D.	1 pair 5 1 2 1 1	
COILS and TRANSFORMERS				
L1 L2 L3,203 L4 L201 L202 L401 L501 T101 T102,103 T201[X,XG,XGH] T201[XE] T202 T501	SLAA4N9 SLDA4N18 RLQY15G5 SLOA4N9 SLF2D29 SLOA2C5 SLMA1Z3-K SLAA4W1-3 SLIA4D51 SLIA4C242 RLI7W105S-Z RLI7W108P-Z RLI2C450 SLT5K55	FM Antenna Coil FM Detector Coil RF Choke Coil FM Oscillator Coil AM Bar Antenna Coil AM Oscillator Coil Low Pass Filter FM Balun Coil FM Discriminator Transformer Muting IF Transformer AM IF Transformer, 1st AM IFT, 1st (Set for England[XE] Only) AM IF Transformer, 2nd Power Transformer	1 1 2 1 1 1 1 1 1 2 1 1 1 1	
CERAMIC FILTERS				
CF101,102,103	SVFF10M12CGG SVFF10M12CGB SVFF10M12CGR SVFF10M12CGW SVFF10M12CGY	FM IF Circuit, Green, 10.6MHz FM IF Circuit, Black, 10.65MHz FM IF Circuit, Red, 10.7MHz FM IF Circuit, White, 10.75MHz FM IF Circuit, Yellow, 10.8MHz	each 3	
RESISTORS				
R503 R122 R113	ERD14TJ2R2 ERD14VJ151 ERD14TJ181	2.2 Ω, 1/4W, ±5%, Carbon 150 Ω, 1/4W, ±5%, Carbon 180 Ω, 1/4W, ±5%, Carbon	1 1 1	

Ref. No.	Part No.	Part Name & Description	Per Set	Remarks
R502 R12 R302 R11 R210	ERD14VJ182 ERD18TJ222 ERD18TJ183 ERD14TJ393 ERD14VJ104	1.8k Ω, 1/4W, ±5%, Carbon 2.2k Ω, 1/8W, ±5%, Carbon 18k Ω, 1/8W, ±5%, Carbon 39k Ω, 1/4W, ±5%, Carbon 100k Ω, 1/4W, ±5%, Carbon	1 1 1 1 1	
VARIABLE RESISTORS				
VR101,301 VR401	EVLS0AA009.4 EVLS0AA00B24	10k Ω(B), Muting & VCO Adjustment 20k Ω(B), Separation Adjustment	2 1	
CAPACITORS				
C13 C123 C5,12,113 C14 C1,6,10,110 205 C3 C11 C107 C2,104,108,114 209 C7 C204 C304 C9,115,122 C4 C206,208,503 C8,201,202 203,210,211 C401,402 C15,102,103, 105,106,111, 112,124,125, 126,127 C16,118,119,121 C212 C101,301 C214 C120 C306,405 C117,501,502, 504 C109,207 C302,305,403, 404 C303 C116	ECCD1H010CC ECCD1H070CC ECCD1H100KC ECCD1H120KR ECCD1H150KC ECCD1H180KC ECCD1H390KC ECCD1H560K ECCD1H101K ECCD1H181K ECQS1361JZ ECQS1471JZ-K ECKD1H102PF ECKD1H102MDA ECKD1H103PF ECKD1H103MD ECQM05123JZ ECKD1H223PF ECQM05223KZ ECQM05333KZ ECQM05473KZ ECAE6V470L ECEA16V10L ECEA16V220L ECEA16V470 ECEA25V3R3L ECEA50MR33 ECEA50MR47 ECEA50NR47	1PF, 50WV, ±0.25pF, Ceramic 7pF, 50WV, ±0.25pF, Ceramic 10pF, 50WV, ±10%, Ceramic 12pF, 50WV, ±10%, Ceramic 15pF, 50WV, ±10%, Ceramic 18pF, 50WV, ±10%, Ceramic 39pF, 50WV, ±10%, Ceramic 56pF, 50WV, ±10%, Ceramic 100pF, 50WV, ±10%, Ceramic 180pF, 50WV, ±10%, Ceramic 360pF, 125WV, ± 5%, Styrol 470pF, 125WV, ± 5%, Styrol 0.001μF, 50WV, ±10%, Ceramic 0.001μF, 50WV, ±20%, Ceramic 0.01μF, 50WV, ±10%, Ceramic 0.01μF, 50WV, ±20%, Ceramic 0.012μF, 50WV, ± 5%, Polyester 0.022μF, 50WV, ±10%, Ceramic 0.022μF, 50WV, ±10%, Polyester 0.033μF, 50WV, ±10%, Polyester 0.047μF, 50WV, ±10%, Polyester 470μF, 6,3WV, Electrolytic 10μF, 16WV, Electrolytic 220μF, 16WV, Electrolytic 470μF, 16WV, Electrolytic 3.3μF, 25WV, Electrolytic 0.33μF, 50WV, Electrolytic 0.47μF, 50WV, Electrolytic 0.47μF, 50WV, Non-Polar Electrolytic	1 1 3 1 5 1 1 1 5 1 1 1 3 3 6 2 11 4 1 2 1 1 1 2 4 1 1	
VARIABLE CAPACITORS				
CV1,2,3,201,202 (CT1,2,3,201, 202)	ECV5MD34X59G	Tuning Gang, FM/AM (with Trimmer)	1	

Ref. No.	Part No.	Part Name & Description	Per Set	Remarks
FUSES and LAMPS				
F501	XBA2C10TRO	Fuse, 1A(T)	1	SAFETY
F502	XBA2C03TRO	Fuse, 315mA(T)	1	SAFETY
PL1,2,3	XAMR53K	Lamp, Dial & Meter (6.3V 0.25A)	3	SAFETY
COMPONENT COMBINATIONS				
Z101	EXA5DL04C	FM Detector Circuit	1	
Z501	RXAF103P22HD	0.01 μ F (X2), Hum Cancel	1	
METER				
	SSM59	Meter, FM Tuning/AM Signal	1	○
SWITCHES				
S1	SSH49S-V	Band Selector Switch	1	○
S2	SSH51S-V	FM Muting Switch	1	○
S3[X, XG, XGH]	ESB7047	Power Source Switch	1	SAFETY
S3 [XE]	ESB7017	Power Switch (for England[XE] Only)	1	SAFETY
S4	ESE372	Voltage Selector Switch	1	○ SAFETY
CABINET and CHASSIS PARTS				
1	SGU21	Dial Plate, Plastic	1	○
2	SGW7190	Panel, Front	1	○
3	XSB3+6FZS	Screw, Front Panel M'tg.	2	
4	SBN535	Knob, Tuning	1	○
5	SGX6433	Sleeve, Push Switches Button	3	
6	XTB3+8B	Screw, Chassis M'tg.	10	
7	SDH337	Cover, Meter & Dial Scale	1	
8	SBC141	Button, Power Switch	1	○
9	SBC139	Button, Selector & Muting Switch	2	
10	SHGA703	Bushing, Push Switch Button	3	
11	SKD2371	Scale, Dial	1	○
12	SXE693-1	Shaft, Pulley Ass'y	1	○
13	SXE697-1	Shaft, Pulley Ass'y	1	○
14	SXE695-1	Shaft, Pulley Ass'y	1	○
15	RNW150-2	Washer, Pulley Lock	4	
16	RDR20	Pulley, Dial Cord	4	
17	SDZ051-1	Cord, Dial	1 roll	
18	SDP1093-1	Pointer, Dial	1	○
	SHP15-1	Paper, Pointer Slider	1	
19	SNWA352	Washer, Nylon	1	
20	SHR401-1	Lock Pin, P.C.B.	1	
21	RJV1A	Holder, Dial Lamp	3	
22	QQC0689	Label, Made in Japan (Set for England[XE] Only)	1	
23	XTB3+8BFZ	Screw, Light Cover & Terminal M'tg.	4	
24	SDSA4121	Spring, Drum	1	
25	SDD47-1	Drum, Dial Cord	1	○
26	XNS11	Nut, Tuning Shaft M'tg.	2	
27	SDT9381	Shaft, Tuning Ass'y	1	○
	SDX751S	Flywheel, Tuning Shaft	1	
	XXAS3K5S	Screw, Flywheel M'tg.	2	
28	SKL149	Foot, Set (with Lock Pin)	4	
29	SJFA206	Holder, Fuse	1	
30	XNG3BS	Nut, Voltage Selector Switch	2	
31	XWA3B	Washer, Voltage Selector Switch	2	
32	XSB3+14FZS	Screw, Voltage Selector Switch M'tg.	2	

Ref. No.	Part No.	Part Name & Description	Per Set	Remarks
33	SUDA41	Spacer, Voltage Selector Switch	2	
34	SJFA4402	Terminal, Ext. Antenna	1	
35[X, XG, XGH]	RHR106	Bushing, AC Cord	1	
35 [XE]	SHR113	Bushing, AC Cord (for England[XE])	1	
36 [X, XG]	SJA95	AC Cord, (for [X] & Germany[XG])	1	SAFETY
36 [XE]	SJA73	AC Cord, (for England[XE] Only)	1	SAFETY
36 [XGH]	SJA81	AC Cord, (for Holland[XGH] Only)	1	SAFETY
37	SMA207	Holder, AM Antenna Coil	1	○
38	SMA205	Holder, AM Antenna Coil	1	○
39	SJF3207	Terminal, AF Output	1	○
40 [X, XG, XGH]	SGP390A	Rear Panel	1	○
40 [XE]	SGP390-1A	Rear Panel (for England[XE] Only)	1	○
41 [X, XE]	SKA8330	Cabinet, Brown Wooden (for [X] & England[XE])	1	○
41 [XG, XGH]	SKA8331	Cabinet, Black Wooden (for Germany[XG] & Holland[XGH])	1	○
42 [X, XE]	SQXA4067	Caution Label, for Brown Cabinet Use	1	
42 [XG, XGH]	SQXA4112	Caution Label, for Black Cabinet Use	1	
43	XWG4FZ	Washer, Cabinet Screw	4	
44	XTB4+16FFZ	Screw, Cabinet M'tg.	4	

ACCESSORIES

A1	SSA251	Cord, 75 Ω FM Antenna	1	○
A2	SJP2129	Cord, Connection	1	
A3 [X]	RJP16AS	Plug, AC (for [X] Only)	1	

PACKINGS

P1	SPPA16-1	Soft Cover	1	
P2	SPP163	Polyethylene Bag	1	
P3	SPS325	Pad, Left & Right Side	1	
P4 [X]	SPN5149	Carton Box, Inner (for [X] Only)	1	○
P5 [X]	SPG619	Carton Box, Outer (for [X] Only)	1	○
P5 [XG, XE]	SPG625	Carton Box (for Germany[XG] & England[XE])	1	○
P5 [XGH]	SPG627	Carton Box (for Holland[XGH] Only)	1	○
P6 [XGH]	SPS333	Pad, Under (for Holland[XGH] Only)	1	
P7[X, XG, XGH]	SQF1173	Printed Matter	1	○
P7 [XE]	SQF1181	Printed Matter (for England[XE] Only)	1	○
P8	SPS481	Pad, Bottom Side	2	

NOTE :

Set for [X] are European, Asia, Latin America, Oceania, Middle East and Africa.